

The energy efficient way
to achieve a dry, healthy home

CLEANAIRE

The Genuine Heat Recovery Ventilator (HRV)



Product Information

All that you need
is the air that you breathe
- make sure its **cleanaire**

The Genuine **CLEANAIRE HRV** controls indoor condensation, humidity, pollutants and odours by replacing stale air with fresh warm outdoor air. Each model has two "almost -silent" fans and an "Air-to-Air" Heat Exchanger that recycles heat otherwise wasted.



Indoor contaminants and condensation are generated at a small but continuous rate. The **CLEANAIRE HRV** provides continuous "trickle ventilation" with fresh outdoor warm dry air. Replacing indoor air once every three hours (8 times per day) ensures that excessive **moisture and indoor contaminants are diluted away**, so the indoor environment is fresh, dry and healthy.

Conventional ventilation with windows, louvres and attic fans waste 100% of exhausted energy thus defeating the very purpose of Energy Efficiency Regulations. Building scientists have assessed that effective, conventional winter ventilation adds approx 20% to home energy costs, and doesn't prevent serious damage by mould and mildew to window sills, wall paper, drapes, furnishings and the structure of your home.



Since producing the first (NZ) genuine home HRV in 1982, **CLEANAIRE HRV** has perfected the "**Crossflow**" **Heat Exchanger**, to suit the NZ climate. What other home ventilation system recovers and recycles up to 800% more energy than it costs to operate, in normal domestic service? Others may imitate, or advertise with words that confuse, but **CLEANAIRE is a genuine HRV.**

Winter

Stale indoor air is not only damp, but **warm**. By the natural laws of physics, when cold air is warmed, it becomes dry air. The heat exchanger captures waste heat from damp polluted exhaust air, then transfers this same heat to the incoming outdoor air. Now warm and dry, the outdoor air is distributed into your home to provide **fresh, healthy and dry indoor environment**. The incoming outdoor air and exhaust air streams are separated at all times to ensure fresh air is delivered to your home.

The **CLEANAIRE HRV** is not a heater or a heat pump - it **recycles waste heat** from other indoor sources and will dehumidify whenever the outdoor air is colder than indoor air. The **CLEANAIRE HRV** performs best when winter conditions are worst. Unlike other condensation control devices.

HRVs do not require sunshine, a warm roof space, or supplementary heating. Genuine HRVs deliver controlled, balanced ventilation 24 hours a day, every day. When there is little or no indoor heat to recover (on warm days and in summer) the HRV continues to provide controlled ventilation from its two (supply and exhaust) fans. Ventilation with fresh outdoor air will ensure "**acceptable indoor air quality**", but for effective condensation control, indoor air must be warmer than outdoor air. The greater the temperature difference (indoors warmer - outdoors colder), the better the **CLEANAIRE HRV** will dehumidify the indoor environment.

Summer

For air-conditioned homes, the HRV recovers and recycles "cooled energy", saving summer energy costs. If the home is unoccupied and secured during the day, leave the HRV **ON**. The **CLEANAIRE HRV is a "trickle ventilator"**. Home designs that attract excessive solar heat may require ventilation at many times more than the capacity of the HRV to provide indoor comfort (larger model solutions available). For homes that are not air-conditioned and your lifestyle is to have windows open in summer, switch the HRV **OFF**. Optional automatic ON/OFF controls are available.

How it Works

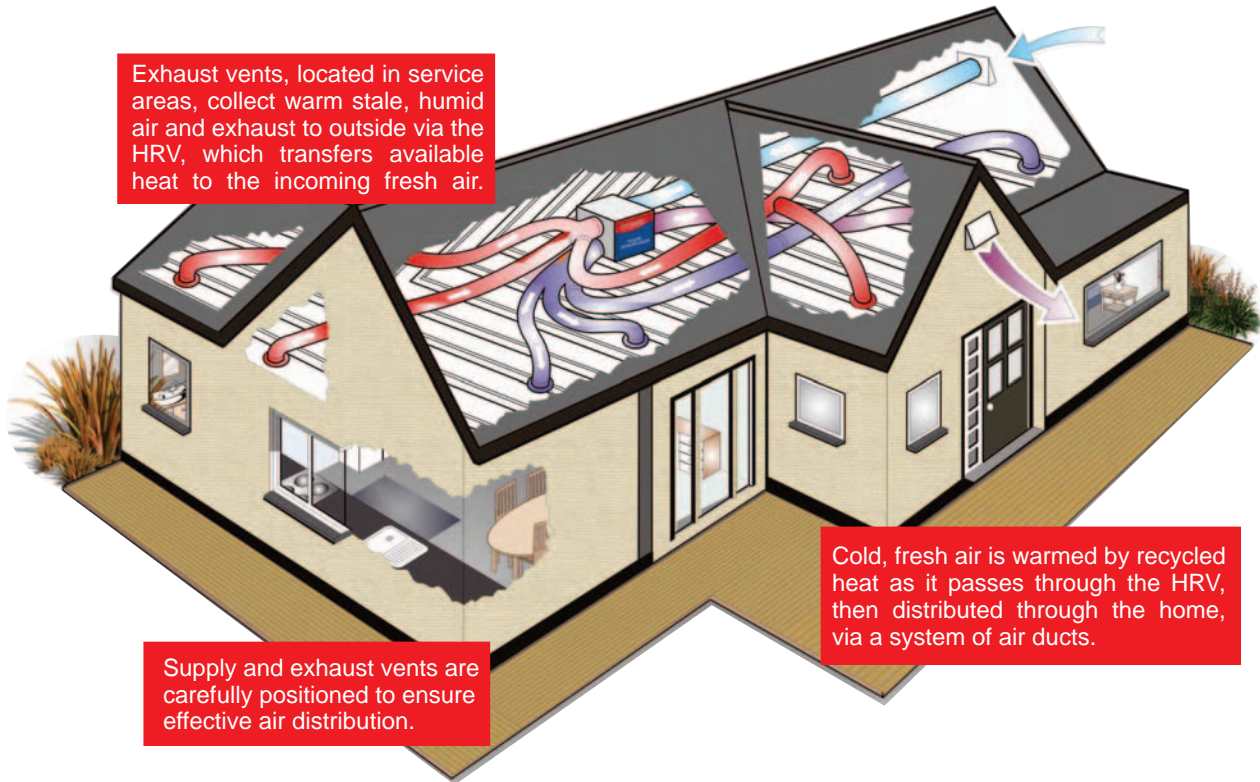

A Genuine HRV must Have:

- ① A **Supply Fan** to bring in fresh outdoor air and distribute this around the home.
- ② An **Exhaust Fan** to remove stale, humid air from the home.
- ③ A **Heat Exchanger** continuously transfers available heat from the exhaust air to the incoming outdoor supply air, heating and drying the incoming cold, outdoor air, and controlling condensation.
- ④ A **Condensate Drain** to outside

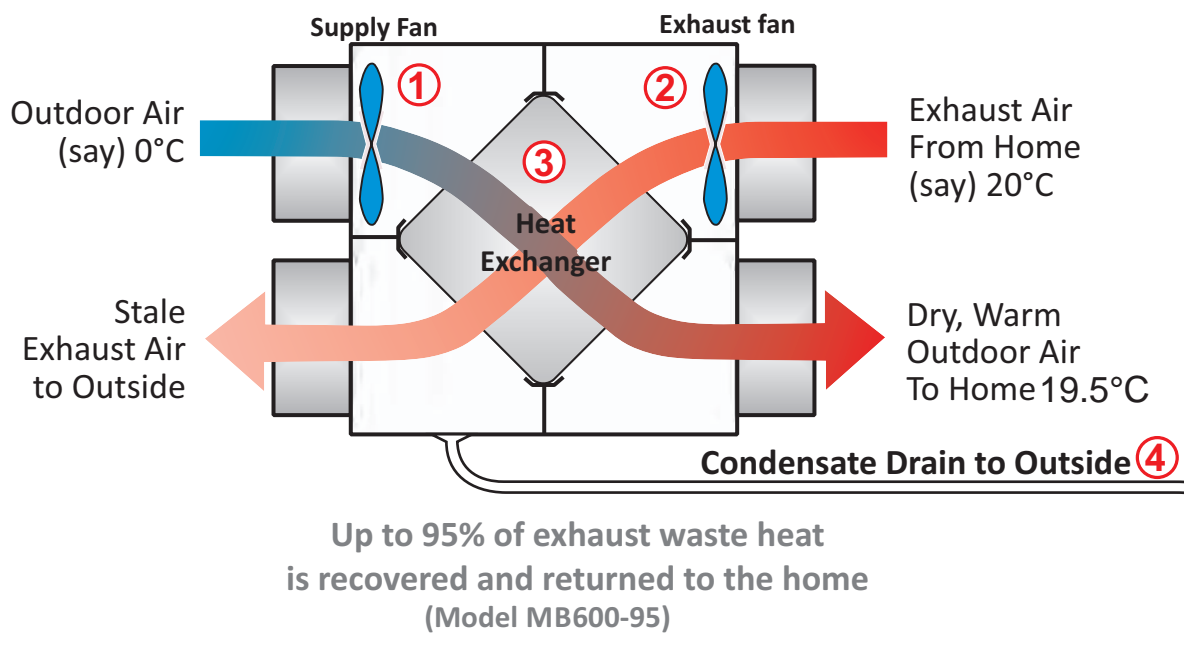

See The Difference

CLEANAIRE

The Genuine Heat Recovery Ventilator (HRV)

Complies with NZ Standard 4303:1990 "Ventilation for Acceptable Indoor Air Quality"

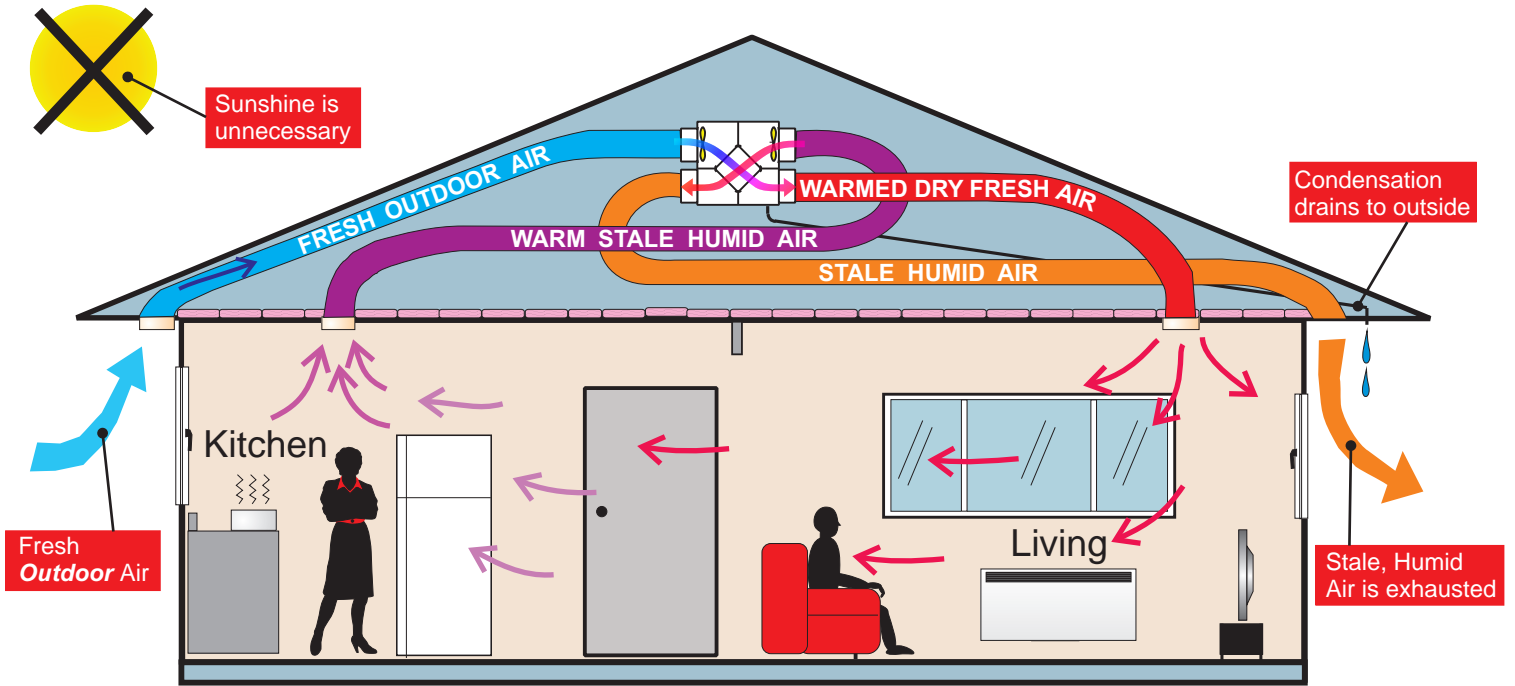

Positive Pressure System - Has No Heat Exchanger!

Does not comply with NZ Standard 4303:1990 "Ventilation for Acceptable Indoor Air Quality"

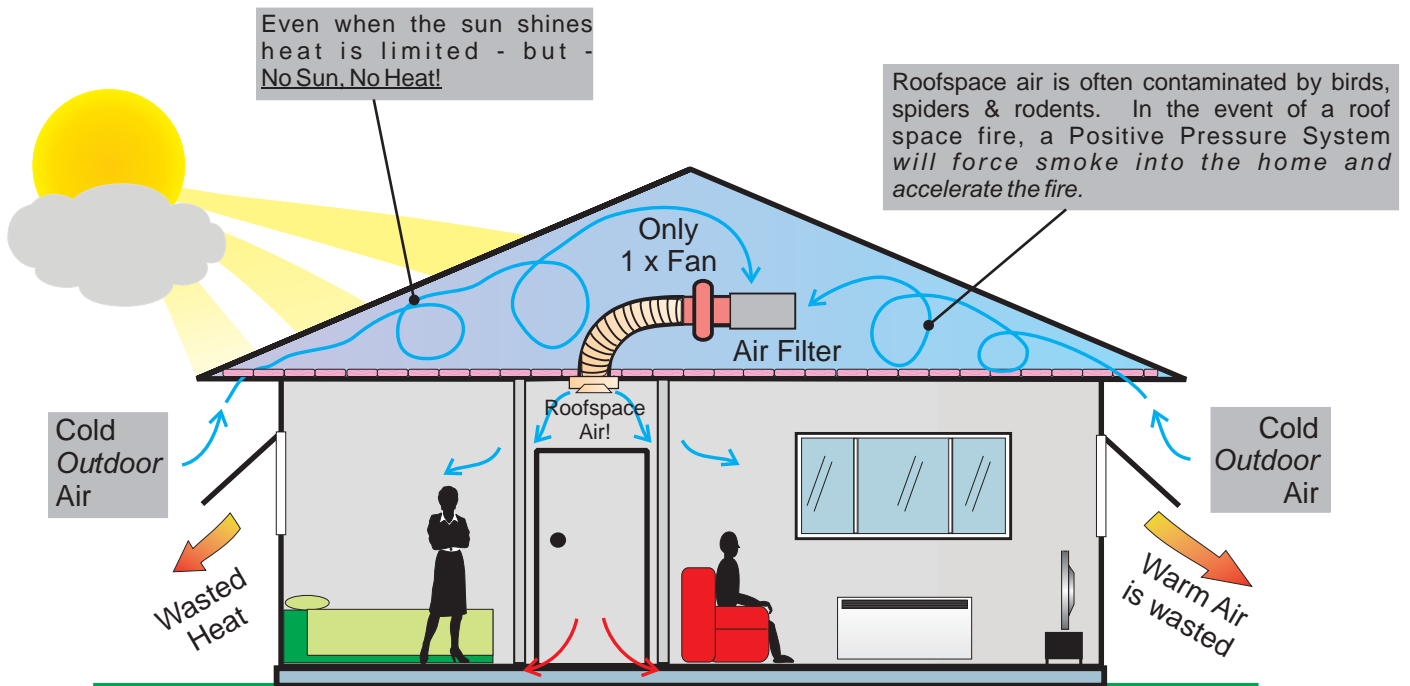

Specifications

Avon currently manufactures three standard domestic **CLEANAIRE HRV** models: the **MA600-80**, **MB600-95** and the **MB800-95**.

Model	MA600-80	MB600-95	MB800-95
Living Space Volume	600m ³	600m ³	800m ³
Power Consumption (low)	80W	80W	80W
Power Consumption (high)	200W	200W	350W
Efficiency (Up to Max)	80% max	95% max	95% max
Weight	26kgs	35kgs	50kgs
Dimensions (mm) (HxWxD)	530x690x430	535x845x425	560x1070x440

Note: Remove duct spigots and access door to reduce dimensions. (inquire for details)

Enquire about larger capacity Avon/CLEANAIRE models

The differences between the standard models are small but allow a more specialised unit for your home. The last two numbers refer to the efficiency and the other three numbers refer to the volume of the home it is designed for (example, the MB600-95 is designed for a home volume up to 600m³ and is up to 95% efficient). The MB models are slightly bigger than the MA models as they hold a larger air to air heat exchange core (the reason the MB600-95 is more efficient than the MA600-80). To accommodate for larger homes, which incorporate more ducting and greater pressure losses, the MB800-95 has larger fans.

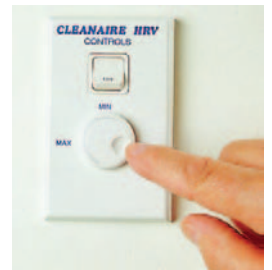

MA600-80 / MB600-95

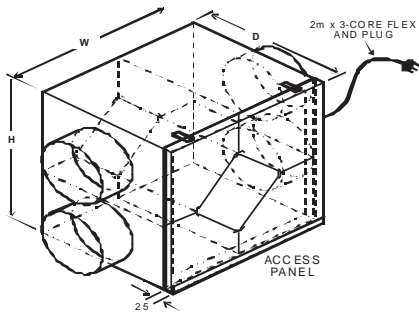

HRV MODEL	H	W	D
MA600-80	530	690	430
MB600-95	535	845	425

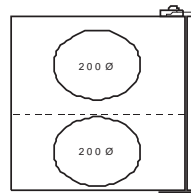
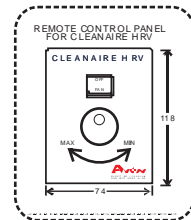
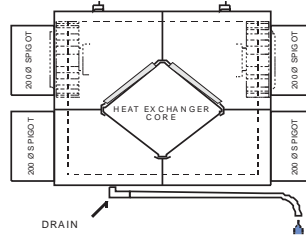
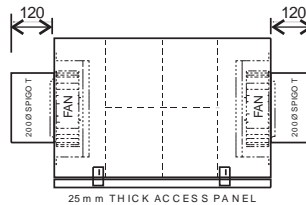

NOT TO SCALE

MB800-95

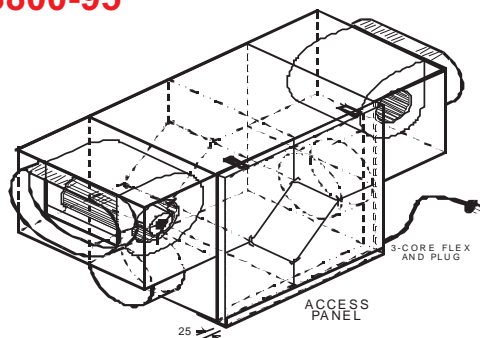

HRV MODEL	H	W	D
MB800-95	560	1070	440

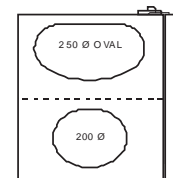
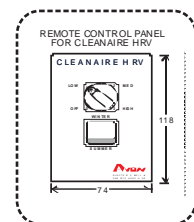
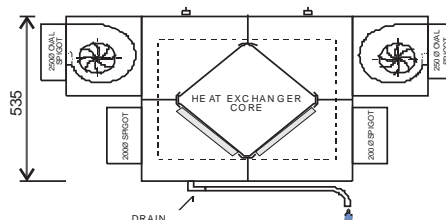
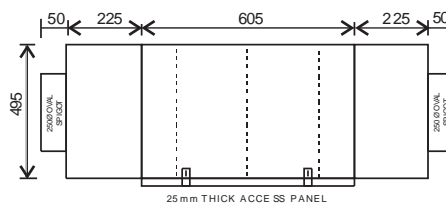

NOT TO SCALE

Optional Extras / Filters



Air Filters

- Common air filters are known as "media air filters" and in general terms graded from 1 to 20. NZ outdoor air is relatively clean. The higher the grade the better the air filter, but more frequent the need for service and maintenance costs. **CLEANAIRE HRV** only supplies outdoor air to the home, simple air filters are sufficient to prevent larger pollens and particulate from entering the home.
- **CLEANAIRE HRV's** have integral No 3 Grade air filters, one for the outdoor air and another for the exhaust air, (which reduces the need to clean the Heat Exchanger). Each filter will remove larger pollens and common outdoor dust.
- Higher grade particulate air filters are required if occupants suffer from Hayfever, allergies, or if outdoor air contains excessive volumes of dust or particulate. No 4 or 5 filters (as used in food factories) are usually sufficient. **Over specified air filters are unnecessary and require more frequent filter maintenance and expense.**
- If outdoor air is polluted by odours from woodsmoke, or industrial or motorway fumes etc, an odour control air filter is necessary. Carbon filters absorb odours from installation until "saturated", (typically lasting 4-6 months).
- For the requirements above, the **CLEANAIRE HRV "Quikfit"** is a simple but effective system which can accommodate several types of filters in the same enclosure. Advantages of the **CLEANAIRE HRV "Quikfit"** bin filter include the large surface area, low replacement cost, long life span and simple to replace. Inquire for further details.
- For more specialised air cleaning systems, inquire for details.

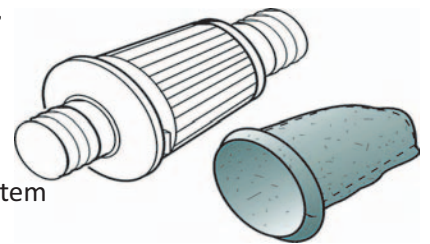

Optional Extras

Hot Water Thermostat

Ideal for new homes and houses where no bathroom ventilation is presently installed. Its function is to increase the rate of ventilation when hot water is used, i.e; A shower, by detecting when the hot water pipe is in use and increasing the fan speed of the **CLEANAIRE HRV** unit to high to compensate for the extra humidity. The fan returns to normal speed when the hot water pipe cools down.

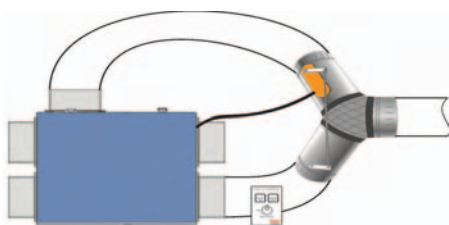

Summer Bypass Damper

The Summer Bypass Damper allows fresh air to bypass the **CLEANAIRE HRV** during the warmer months. The airflow can also be increased during this time to create a refreshing 'breeze' through the home. Please contact us for more information.

"Cut in Half" Kitset

If roofspace access is restricted by a smaller or hard to get at manhole we offer to supply the **CLEANAIRE HRV** as a "Knock-down Kitset" that enables the HRV to be passed through the manhole and reassembled in the roofspace. This option includes everything needed to reassemble.

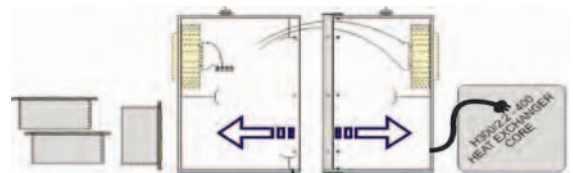

For more information on these and other optional extras available please contact us on 0800 379 247 to discuss

Additional Information

CLEANAIRE HRV's are designed to ventilate homes with fresh outdoor air at the rate recommended in NZ Standard 4303 "**Ventilation for Acceptable Indoor Air Quality**" ie. one air change every 3 hours. Each model has two ultra-quiet fans, one to exhaust stale humid air and another "supply fan" to replace **exhausted** air with dry warm outdoor air. Heat from the warm exhaust air stream is "captured" by a heat exchanger and **recycled** to preheat the incoming cold, fresh **outdoor** air. The fresh outdoor air becomes dry when it is warmed by the heat exchanger. Introducing fresh, warm, dry air into your home **evaporates and controls condensation** (similar to a motor car windscreen warm air demister, or hair or clothes dryers).

Polluted, damp indoor air is continuously exhausted and replaced by 100% fresh **outdoor air**. Excess humidity is positively exhausted to outside with the foul air and, in some conditions, humidity condenses on the heat exchanger plates (exhaust side only) to be disposed of by the HRV drain.

Continuous **trickle ventilation** with fresh, warm **outdoor** air dilutes indoor air contaminants, which are positively removed by the exhaust fan. The result is an indoor environment that is always fresh and healthy.

The **CLEANAIRE HRV** performs best when winter conditions are **at their worst**, day and night. In an average (heated) home, additional heat (or sunshine) is unnecessary.

Benefits

- **Removes condensation and reduces humidity, looking after home and health.**
- **Continuously exhausts stale, humid, polluted air and replaces it with filtered dry, warmed (Winter) outdoor air.**
- **Helps distribute a more even temperature throughout the home.**
- **Saves energy - up to 15 times more than it costs to run.**
- **Complies with NZ Standard 4303:1990 "Ventilation for Acceptable Indoor Air Quality" (When installed to our plans).**



New Homes

Why install more Open Sash Windows than you really need? These are an additional expense, waste energy and are a security risk.

When designing a new home, inspect the plan carefully, to identify some **opening windows that have been provided solely to comply with the Building Code "5% floor area" rule**, but you know, (even before the home is built), that some of these windows will never be opened.

At the design stage of a new or refurbished home, there is opportunity to replace some windows with fixed sash windows. The \$ savings will make a significant contribution to the installation cost of a **CLEANAIRE HRV**.

The NZ Building Code, Section G4, (VENTILATION), requires new homes to comply, by incorporating "opening windows" with an "openable" area, equal to 5% of the floor area, **OR by installing a Mechanical Ventilation System that complies with NZ Standard 4303:1990 "Ventilation for Acceptable Indoor Air Quality"**



In most new homes, owners can identify 5 to 8 opening windows which can be converted from opening sash windows to fixed pane windows, while still leaving sufficient opening window for Summer ventilation.

To gain a Building Consent, the **CLEANAIRE HRV** System MUST be designed and installed in accordance with NZS4303. Avon provides certification for Consent Authority Approval (A Producer Statement).

Please free phone to discuss on 0800 379 247.

Free Home Consultation



- Replaces stale indoor air with fresh, dry, warm outdoor air.
- Controls condensation and reduces humidity throughout winter.
- Removes Asthma allergens, pollutants and household odours.
- Transfers surplus heat around the home.
- Co² emissions are reduced when energy is recycled.
- DIY or Fully Installed

0800 379 247

CLEANAIRE The Genuine Heat Recovery Ventilator (HRV)

Avon Electric Ltd is a privately owned Christchurch company, first established in 1939, specialising in all Energy Efficient HVAC applications. Avon has been manufacturing the Cleanaire HRV for over 30 years, offering unparalleled experience and a warranty to match.

AVON
Electric Ltd

Avon Electric Ltd
25 Taurus Place, Bromley
Christchurch
Ph (03) 381 5595
Fax (03) 381 5596
info@avonelectric.co.nz
www.dryair.co.nz