



- Ambient, no heat
- 3–18 kW Electrical heat
- Water heat

Lengths: 1, 1,5 and 2 metres



Thermozone® AR200

Recessed air curtains for installation heights up to 2,5 metres

Application

AR200 is especially suited for environments with high demands in respect of design. It is recessed in ceilings above entry doors and other small doors where the height is no greater than 2,5 metres. A low height makes it possible to install AR200 where ceiling space is limited. The recessed installation and low sound level makes AR200 very discreet.

Comfort

AR200 creates an air barrier, which prevents cold draughts and ensures comfortable heating inside the door. An adjustable air blower grille makes it possible to direct the air for an optimal air curtain effect. AR200, with heat, can also contribute to the heating of the room when the door is closed.

Operation and economy

Thanks to Thermozone Technology AR200 saves energy. The air barrier reduces energy losses through the door opening and the energy consumption of the air curtain is also low. With an air curtain as a heat source it produces heat in the area where it is most needed, and as a result the rest of the premises can be covered with less output. Easy installation and maintenance minimizes the cost and the risk of errors.

Design

AR200 is designed for recessed installation and the visible bottom plate may be painted to make it blend even better with the premises.

Product specifications

- Just one model per length, but electrical units are convertible between several outputs and 230V~/400V3N~ making it simple and flexible to adapt the output to current need.
- Optimized airflow with Thermozone Technology.
- Low unit height (200 mm).
- Bottom plate in white lacquered aluminium. Colour: RAL 9016, NCS 0500. The bottom plate can easily be removed and painted in an optional colour. Non visible parts made of hot zinc plated steel panels.

Air velocity profile

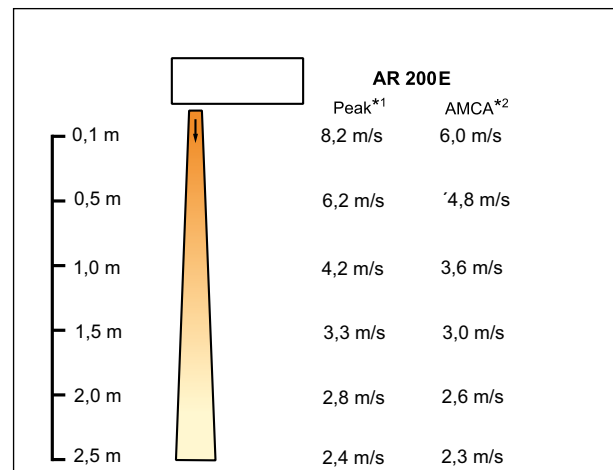

*¹) Peak values

*²) Mean values. Measurements made according to AMCA 220 "Test methods for Air Curtain Units"

Technical specifications | Thermozone AR 200 A without heat ⚡

Type	Output	Airflow	Sound level*1	Voltage	Amperage	Length	Weight
	[kW]	[m³/h]	[dB(A)]	[V]	[A]	[mm]	[kg]
AR210A	0	650/1200	34/50	230V~	0,5	1042	18
AR215A	0	950/1750	34/50	230V~	0,6	1552	25
AR220A	0	1300/2400	40/54	230V~	1,0	2042	36

Technical specifications | Thermozone AR 200 E electrically heated ⚡

Type	Output steps 400V3N~	Output steps 230V~	Airflow	Sound level*1	Δt*2	Voltage	Amperage 400V3N~	Amperage 230V~	Length	Weight
	[kW]	[kW]	[m³/h]	[dB(A)]	[°C]	[V]	[A]	[A]	[mm]	[kg]
AR210E09	0/3	-	650/1200	34/50	13/7	400V3N~	4,3	-	1042	23
	0/6/9	-	650/1200	34/50	41/22	400V3N~	13	-	1042	23
	-	0/3	650/1200	34/50	13/7	230V~	-	13	1042	23
	-	3/5	650/1200	34/50	23/12	230V~	-	22	1042	23
AR215E11	0/4,5	-	950/1750	34/50	14/8	400V3N~	6,5	-	1552	32
	0/6,8/11,3	-	950/1750	34/50	35/20	400V3N~	16	-	1552	32
	-	0/4,5	950/1750	34/50	14/8	230V~	-	20	1552	32
	-	0/4,5/6,8	950/1750	34/50	21/12	230V~	-	30	1552	32
AR220E18	0/6	-	1300/2400	40/54	13/7	400V3N~	8,7	-	2042	44
	0/12/18	-	1300/2400	40/54	41/22	400V3N~	26	-	2042	44
	-	0/6	1300/2400	40/54	13/7	230V~	-	26	2042	44
	-	0/6/10	1300/2400	40/54	23/12	230V~	-	43	2042	44

Technical specifications | Thermozone AR 200 W water heated 💧

Type	Output*3	Airflow	Sound level*1	Δt*2,3	Watervolume	Voltage	Amperage	Length	Weight
	[kW]	[m³/h]	[dB(A)]	[°C]	[l]	[V]	[A]	[mm]	[kg]
AR210W	5.5/7	700/1000	41/49	24/21	0.5	230V~	0.4	1042	21
AR215W	8/11	1000/1600	37/50	24/20	0.9	230V~	0.6	1552	30
AR220W	11/14	1400/2000	44/53	23/20	1.1	230V~	1.0	2042	42

*1) Conditions: Distance to the unit 5 metres. Directional factor: 2. Equivalent absorption area: 200 m². At lowest/highest airflow.

*2) Δt = temperature rise of passing air at maximum heat output and lowest/highest airflow.

*3) Applicable at water temperature 80/60 °C, air temperature, in +15 °C.

AR200E is delivered as 9 kW, 11 kW and 18 kW (400V3N~) models, but they are convertible to 230V~ and different outputs as shown in above table.

Protection class AR200A/E/W: normal design (IP20).
CE compliant.



Design and specifications are subject to change without notice.

Dimensions

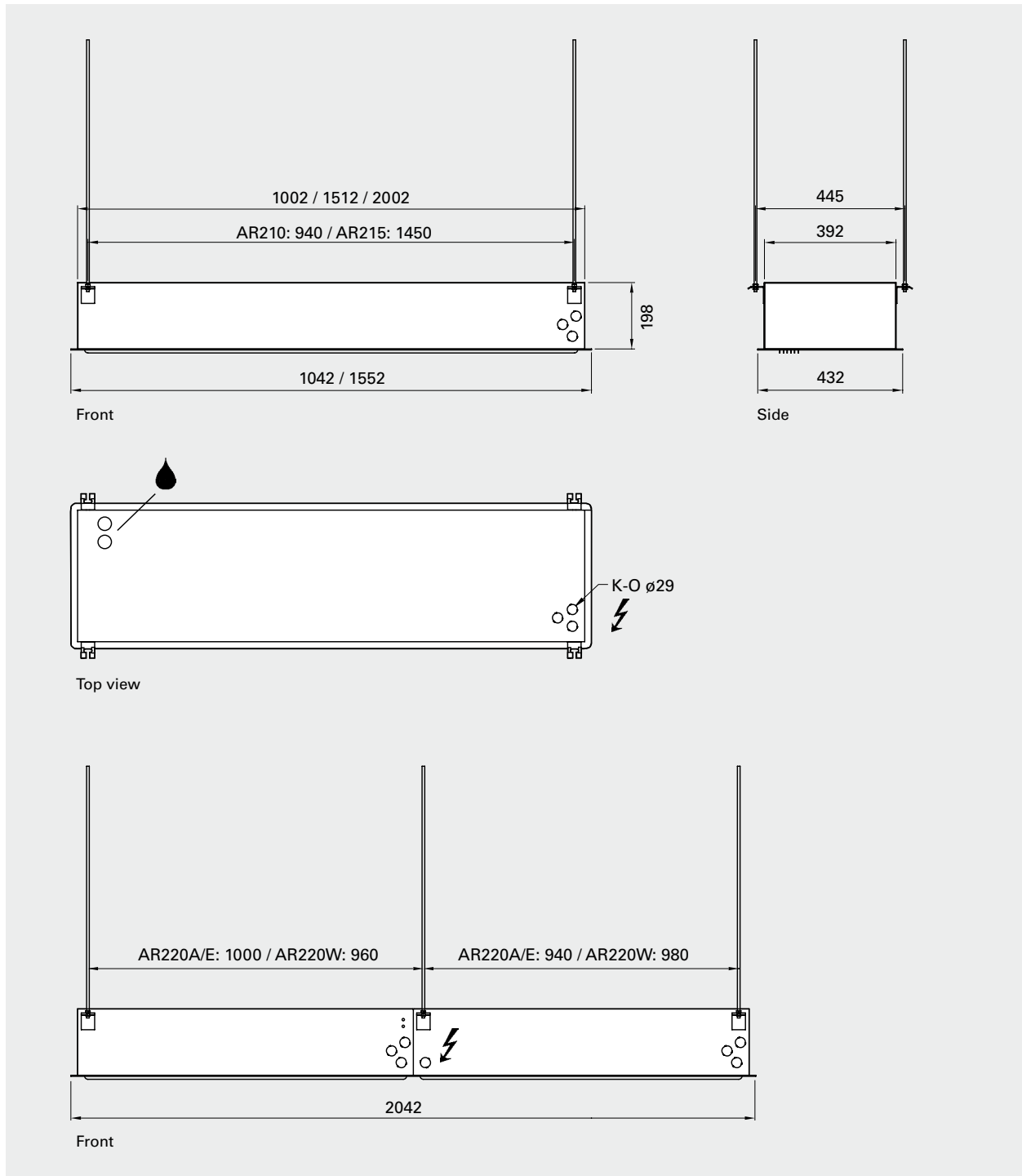

Mounting and connection

Mounting

AR200 unit is installed horizontally with the supply air grille facing downwards as close to the door as possible, concealed in the false ceiling. The only visible part of the unit is the underside that is level with the ceiling.

For the protection of wider doorways, several units can be mounted next to each other. Ensure that the bottom plate is accessible and can be fully opened. Minimum distance from outlet to floor for electrically heated units is 1800 mm, see Fig. 1.

Connection AR 200 A ⚡

The connection to the unit's side or top is made with 2x1.5 mm² + earth. See Wiring Diagram.

Connection AR 200 E ⚡

Connection is made on the top or on the side of the unit with a five-wired cable with earth. The supply terminal block is intended for a cable of maximum 16 mm². See wiring diagrams. The units are convertible between different output and 230V~/400V3N~.

Connection AR 200 W ⚡

The control cable is connected via knock outs to the unit's side or top, with 2x1.5 mm² + earth. Connections (DN15 (1/2"), inside thread) to the water heating coil are located on the top of the unit to the right (seen from inside the building). For AR220W the water connection is located in the middle of the top side of the unit. See wiring diagrams and dimension drawings.

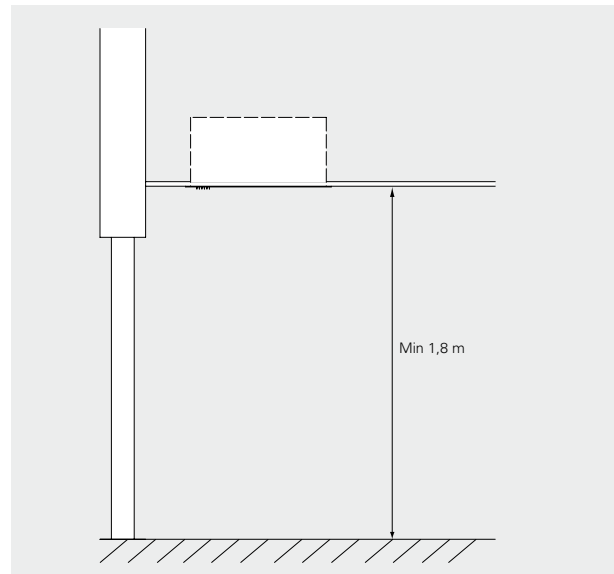

Fig. 1: Minimum distance to floor for electrically heated units.

Control kits

Ambient ✨

Level 1

Airflow is controlled manually

Control kit:

- CB30N, control box , controls the airflow in 3 steps.

Electrical ⚡

Level 1

Airflow is regulated manually. Room thermostat controls the heat output in 2 steps.

Control kit CK01E:

- CB32N, control box, controls the airflow in 3 steps and heat output in 2 steps
- RTI2, 2-step room thermostat (option KRT2800)

Level 2

Airflow and heat output are controlled automatically based on the opening of the door and the room temperature. When the door is open the fan runs on high speed, when the door closes the fan will continue to run on high speed for the desired time (2s–10 min.) set on MDC. When the door is closed the fan runs on low speed if there is a need for heating, if not the fan is switched off.

The room thermostat controls the heat output. E.g. the thermostat is set on 23 °C and the difference between the stages 4 °C. The thermostat will activate below 19 °C when the door is closed. When the door opens, the thermostat will activate below 23 °C and normally the heat is switched on.

Control kit CK02E:

- CB32N, control box, controls the airflow in 3 steps and heat output in 2 steps
- MDC, door contact with time delay
- RTI2, 2-step room thermostat (option KRT2800)

💧 Unit with water heating

Level 1

Airflow is controlled manually. Room thermostat controls the heat output via actuator/valve on/off.

Control kit CK01W:

- CB30N, control box , controls the airflow in 3 steps.
- T10, room thermostat IP30.

Note! A set of valves VR20 or VR25 or actuator+valve SD20+TVV20 or TVV25 should be added for a complete control kit.

Level 2

Airflow and heat output are controlled automatically based on the opening of the door and the room temperature. When the door is open the fan runs on high speed, when the door closes the fan will continue to run for the desired time (2s–10 min.) set on the MDC. When the door is closed the fan runs on low speed if there is a need for heating, if not the fan is switched off.

The room thermostat controls the heat output on/off. E.g. the thermostat is set on 23 °C and the difference between the stages 4 °C. The thermostat will activate below 19 °C when the door is closed. When the door opens, the thermostat will activate below 23 °C and normally the heat is switched on.

Control kit CK02W:

- CB30N, control box, controls the airflow in 3 steps.
- MDC, magnetic door contact with time delay.
- RTI2, 2-step room thermostat.

Note! A set of valves VR20 or VR25 or actuator+valve SD20+TVV20 or TVV25 should be added for a complete control kit.

Output charts water

Incoming / outgoing water temperature 90/70 °C										
			Incoming air temp. = +15 °C				Incoming air temp. = +20 °C			
Type	Fan position	Airflow [m³/s]	Output [kW]	Air temp. out [°C]	Water flow [l/s]	Pressure drop [kPa]	Output [kW]	Air temp. out [°C]	Water flow [l/s]	Pressure drop [kPa]
AR210W	max	1000	8,5	40	0,1	24,9	7,5	43	0,09	21,6
	min	700	6,5	43	0,08	16,8	6	46	0,08	14,6
AR215W	max	1600	13,5	40	0,16	13,4	12,5	43	0,15	11,5
	min	1000	10	45	0,10	7,9	9	47	0,11	6,8
AR220W	max	2000	16,6	40	0,2	22,8	15,5	43	0,19	19,7
	min	1400	13,5	43	0,16	15,3	12,5	46	0,15	15,3

Incoming / outgoing water temperature 80/60 °C										
			Incoming air temp. = +15 °C				Incoming air temp. = +20 °C			
Type	Fan position	Airflow [m³/s]	Output [kW]	Air temp. out [°C]	Water flow [l/s]	Pressure drop [kPa]	Output [kW]	Air temp. out [°C]	Water flow [l/s]	Pressure drop [kPa]
AR210W	max	1000	7	36	0,08	18,2	6,5	39	0,08	15,3
	min	700	5,5	39	0,07	12,4	5	41	0,06	10,4
AR215W	max	1600	11	35	0,13	9,7	10	38	0,12	8,1
	min	1000	8,5	39	0,10	5,8	7,5	42	0,09	4,8
AR220W	max	2000	14	35	0,17	16,6	12,5	38	0,15	13,9
	min	1400	11	38	0,14	11,2	10	41	0,12	9,4

Incoming / outgoing water temperature 60/50 °C										
			Incoming air temp. = +15 °C				Incoming air temp. = +20 °C			
Type	Fan position	Airflow [m³/s]	Output [kW]	Air temp. out [°C]	Water flow [l/s]	Pressure drop [kPa]	Output [kW]	Air temp. out [°C]	Water flow [l/s]	Pressure drop [kPa]
AR210W	max	1000	5	30	0,12	38,6	4,5	33	0,11	30,2
	min	700	4	32	0,10	26,1	3,5	35	0,09	20,4
AR215W	max	1600	8	30	0,20	20,7	7	33	0,17	16,1
	min	1000	6	33	0,15	12,3	5,5	35	0,13	9,6
AR220W	max	2000	9,5	28	0,23	26,3	8	32	0,20	20,4
	min	1400	7,5	31	0,18	17,9	6,5	33	0,16	14

Incoming / outgoing water temperature 60/40 °C										
			Incoming air temp. = +15 °C				Incoming air temp. = +20 °C			
Type	Fan position	Airflow [m³/s]	Output [kW]	Air temp. out [°C]	Water flow [l/s]	Pressure drop [kPa]	Output [kW]	Air temp. out [°C]	Water flow [l/s]	Pressure drop [kPa]
AR210W	max	1000	4	27	0,05	7,5	3,5	30	0,04	5,4
	min	700	3,5	29	0,04	5,1	3	32	0,03	3,7
AR215W	max	1600	6,5	27	0,08	3,9	5,5	30	0,06	2,8
	min	1000	5	29	0,06	2,3	4	32	0,05	1,7
AR220W	max	2000	8	27	0,10	6,8	7	30	0,08	4,9
	min	1400	6,5	29	0,08	4,6	5,5	31	0,07	3,3