

PA3500



PA3500

Stylish air curtain for commercial premises, with intelligent control

- Horizontal mounting
 - Recommended installation height 3,5 m*
 - Lengths: 1, 1,5, 2 and 2,5 m
- Vertical mounting
 - Recommended installation width 5 m* (2 units), one on each side
 - Lengths: 1,5, 2 and 2,5 m

- ✿ Ambient, no heat
- ⚡ Electrical heat: 8 - 20 kW
- 💧 Water heat WH, WL, WLL



Optimized airflow with Thermozone technology.

Air velocity profile

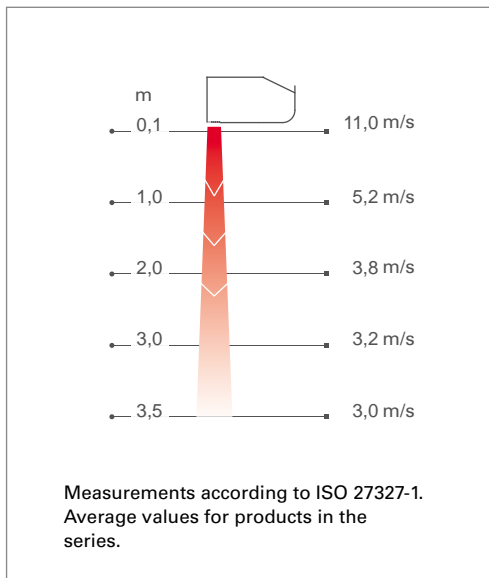

Application

Air curtain PA3500 gives more possibilities than ever before, packed into the same product. There are therefore many areas of use. PA3500 is particularly suitable for entrances to stores and shopping centres for example.

The air curtain has many intelligent and energy saving features which provide fully automatic protection for the entrance, adaptable to each area of use.

Design

Through its timeless design and its many accessories, it's easy to get PA3500 to blend well into the premises. Front and service hatch can be finished in any colour to perfectly match the environment. The air curtain is available for horizontal, vertical and recessed installation.

Product specifications

- Prepared for the SIRE control system whose pre-programmed default settings and many features make it easy to install and use the air curtain. Read more about the SIRE controls package in the "Controls" section.
- The front is easy to open and lock in the open position, which facilitates installation and allows easy maintenance.
- The air curtain is complemented with a vertical pack for vertical installation.
- Outlet extension for recessed installation is available as an accessory.
- The accessory Design kit enables a neat installation with concealed mountings, pipes and cables.
- Corrosion proof housing made of hot zinc-plate and powder enamelled steel panels. Colour front and service hatch: white, RAL 9016, NCS S 0500-N. Colour grille, rear section and ends: grey, RAL 7046.

Technical specifications

🌀 Ambient, no heat - PA3500 A

Type	Output [kW]	Airflow* ¹ [m ³ /h]	Sound level* ² [dB(A)]	Output- motor [W]	Voltage motor [V]	Amperage motor [A]	Length [mm]	Weight [kg]
PA3510A	0	860/1800	40/57	470	230V~	2,0	1039	36
PA3515A	0	1240/2600	40,5/58,5	650	230V~	2,8	1549	50
PA3520A	0	1530/3200	42/59,5	810	230V~	3,5	2039	65
PA3525A	0	2200/4600	42/60,5	1140	230V~	4,9	2549	79

⚡ Electrical heat - PA3500 E

Type	Output step [kW]	Airflow* ¹ [m ³ /h]	Δt * ³ [°C]	Sound level* ² [dB(A)]	Output- motor [W]	Voltage motor [V]	Amperage motor [A]	Voltage [V] Amperage [A] (heat)	Length [mm]	Weight [kg]
PA3510E08	2,7/5,4/8,1	860/1800	35/13	40/57	470	230V~	2,0	400V3~/11,7	1039	44
PA3515E12	3,9/7,8/11,7	1240/2600	38/14	40,5/58,5	650	230V~	2,8	400V3~/16,9	1549	63
PA3520E16	5,4/10,8/16,2	1530/3200	35/13	42/59,5	810	230V~	3,5	400V3~/23,4	2039	80
PA3525E20	6,6/13,2/19,8	2200/4600	37/14	42/60,5	1140	230V~	4,9	400V3~/28,6	2549	104

💧 Water heat - PA3500 WH, coil for high temperature water (≥ 80 °C)

Type	Output* ⁴ [kW]	Airflow* ¹ [m ³ /h]	Δt * ^{3,4} [°C]	Water volume [l]	Sound level* ² [dB(A)]	Output- motor [W]	Voltage motor [V]	Amperage motor [A]	Length [mm]	Weight [kg]
PA3510WH	10,2	860/1800	22/17	1,0	40/57	470	230V~	2,0	1039	42
PA3515WH	15,3	1240/2600	23/17	1,6	40,5/58,5	650	230V~	2,8	1549	58
PA3520WH	20,1	1530/3200	24/19	2,2	42/59,5	810	230V~	3,5	2039	73
PA3525WH	27,4	2200/4600	23/18	2,9	42/60,5	1140	230V~	4,9	2549	92

💧 Water heat - PA3500 WL, coil for low water temperature (≤ 80 °C)

Type	Output* ⁵ [kW]	Airflow* ¹ [m ³ /h]	Δt * ^{3,5} [°C]	Water volume [l]	Sound level* ² [dB(A)]	Output- motor [W]	Voltage motor [V]	Amperage motor [A]	Length [mm]	Weight [kg]
PA3510WL	11,7	860/1800	24/19	1,5	40/57	470	230V~	2,0	1039	43
PA3515WL	18,1	1240/2600	26/21	2,4	40,5/58,5	650	230V~	2,8	1549	60
PA3520WL	22,8	1530/3200	26/21	3,3	42/59,5	810	230V~	3,5	2039	75
PA3525WL	32,6	2200/4600	26/21	4,2	42/60,5	1140	230V~	4,9	2549	95

💧 Water heat - PA3500 WLL, coil for very low temperature water (≤ 60 °C)

Type	Output* ⁶ [kW]	Airflow* ¹ [m ³ /h]	Δt * ^{3,6} [°C]	Water volume [l]	Sound level* ² [dB(A)]	Output- motor [W]	Voltage motor [V]	Amperage motor [A]	Length [mm]	Weight [kg]
PA3510WLL	7,2	830/1700	15/13	2,0	40/57	470	230V~	2,0	1039	44
PA3515WLL	10,5	1200/2500	14/12	4,1	40,5/58,5	650	230V~	2,8	1549	63
PA3520WLL	14,0	1460/3050	16/14	5,6	42/59,5	810	230V~	3,5	2039	78
PA3525WLL	19,4	2100/4400	15/13	8,3	42/60,5	1140	230V~	4,9	2549	100

*¹) Lowest/highest airflow of totally 5 fan steps.

*²) Conditions: Distance to the unit 5 metres. Directional factor: 2. Equivalent absorption area: 200 m².

*³) Δt = temperature rise of passing air at maximum heat output and lowest/highest airflow.

*⁴) Applicable at water temperature 80/60 °C, air temperature, in +18 °C.

*⁵) Applicable at water temperature 60/40 °C, air temperature, in +18 °C.

*⁶) Applicable at water temperature 40/30 °C, air temperature, in +18 °C.

Protection class for units with electrical heating: IP20.

Protection class for units without heating and units with water heating: IP21.

CE compliant.

Dimensions

Horizontal mounting

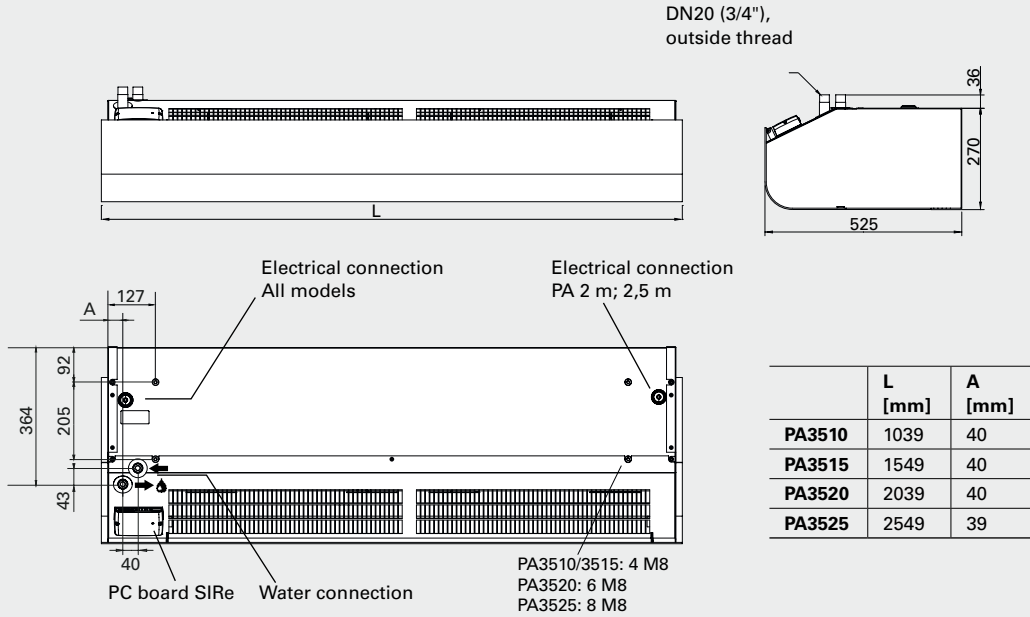

Vertical mounting

The unit can be reversed and placed on either side of the door. Connections and PC Board SIRE are positioned near floor level when the air curtain is placed to the left of the door and at the top when it is placed to the right (seen from the inside).

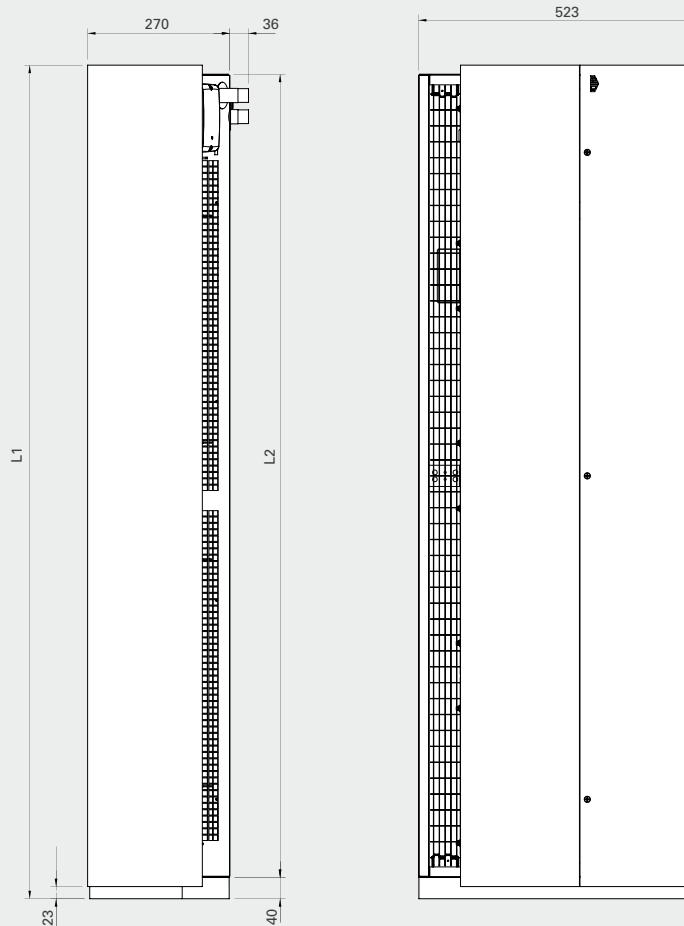

	L1 [mm]	L2 [mm]
PA3515	1572	1515
PA3520	2062	2004
PA3525	2572	2515

Mounting

The air curtain range can be adapted for vertical or horizontal installation. The units can also be installed recessed into suspended ceilings.

Horizontal mounting

The air curtain is installed horizontally with the supply air grille facing downwards as close to the door as possible.

A variety of installation options are available; brackets for wall mounting, threaded bars or cables for ceiling mounting. An outlet extension is used for recessed installation.

The design kit that conceals cables, pipes and mountings is available for both wall and ceiling installations.

For the protection of wider openings, several units can be mounted next to each other using a joining kit.

Minimum distance from outlet to floor for electrically heated units is 1800 mm.

Vertical mounting

Units from 1,5 metres and longer may be used vertically. The air curtain is mounted vertically as close as possible to the door. For the best effect air curtains should be placed on both sides of the opening.

For vertical mounting, each unit must be supplemented with a vertical kit. The design kit for vertical mounting is used to hide pipes and cables.

Two units can be mounted directly on top of each other.

The unit can be reversed and placed on either side of the door. Connections and PC Board SIRE are positioned near floor level when the air curtain is placed to the left of the door and at the top when it is placed to the right (seen from the inside).

The air curtain is mounted on a floor frame that is included in the vertical kit. The edging is attached horizontal to the floor using fasteners appropriate for the surface. The air curtain must always be secured at the top.

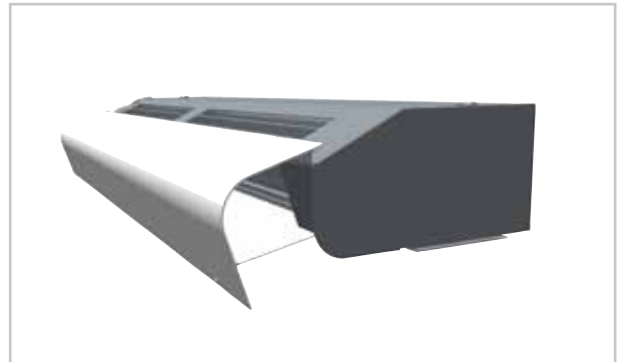

The front is easy to open and lock in the open position, which facilitates installation and allows easy maintenance.

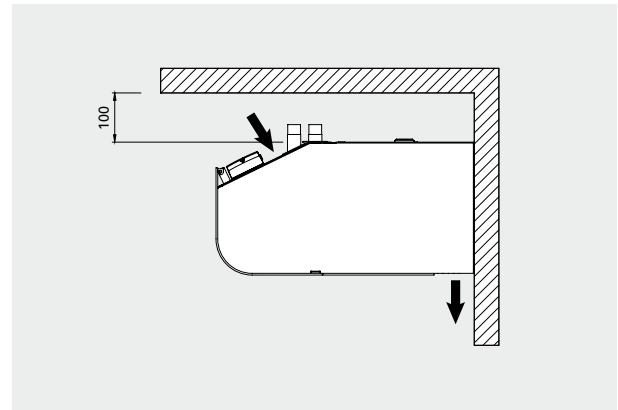

Minimum distances

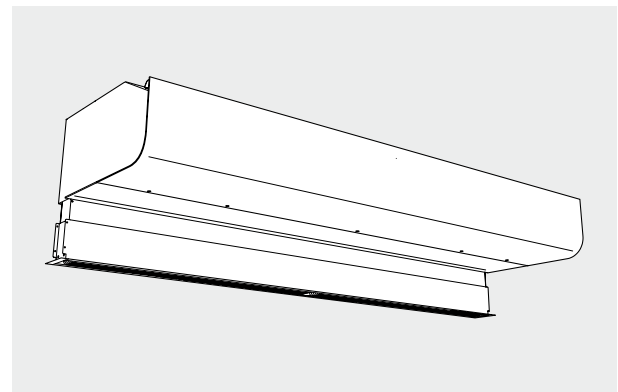

Outlet extension for recessed installation

Connection

The PC board SIRE is built into the air curtain on delivery and is equipped with modular connectors for easy connection of external components. Read more about the SIRE control system in the "Controls" section.

Unit without heating

Connected via the built-in control board with 2 m cord and plug.

Unit with electrical heating

The electrical connection is made on the top of the unit (horizontal) or on the reverse (vertical). Control supply is 230V~ and cable is routed from the built-in SIRE control board. Power supply for heating (400V3 ~) is connected to terminal block in the internal connection box. 2-metre and longer units require dual power supplies.

Unit with water heating

Connected via the built-in control board with 2 m cord and plug.

The water coil is connected on top of the unit (horizontal mounting) or on the reverse (vertical mounting) via connections DN20 (3/4"), external thread. Flexible hoses are available as an accessory.

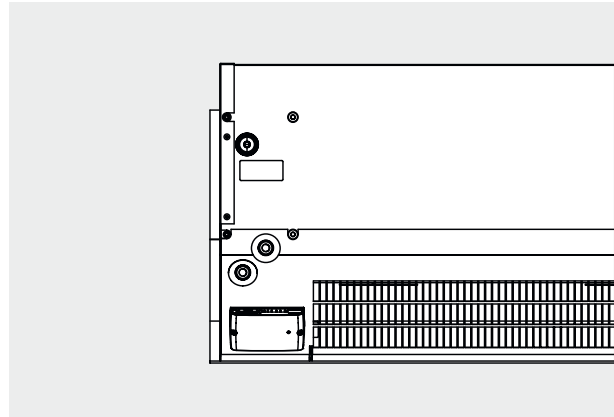

PC board SIRE is built in to the air curtain.



Accessories

Horizontal mounting

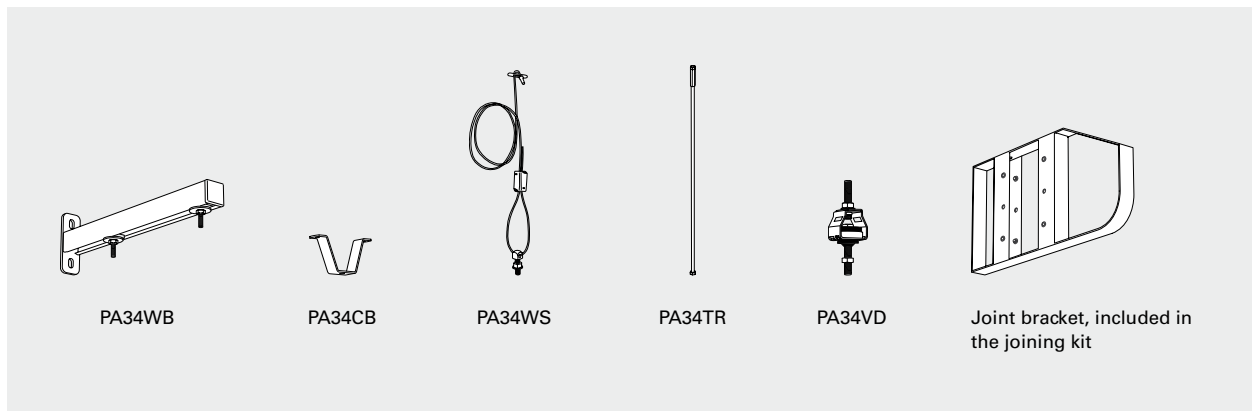
**PA34WB, wall brackets**

Brackets for installing unit horizontally on a wall.

PA34CB, ceiling brackets

Ceiling brackets for installing the unit from the ceiling using wires or threaded bars (not included). Best combined with vibration dampers (PA34VD) when using threaded bars.

PA34WS, wire suspension kit

Galvanized wires with wire locks to secure the unit from the ceiling. Length 3 m. Used together with ceiling brackets (PA34CB).

PA34TR, threaded bars

Threaded bars for installing unit on to a ceiling. Length 1 m. Used together with ceiling brackets (PA34CB). Supplemented with vibration dampers (PA34VD) for reduced vibration.

PA34VD, vibration dampers

Reduces vibrations for ceiling installations with threaded bars.

PA3JK, joining kit

Used to join horizontal units together for a sleek and unified installation. Consists of joint bracket and mounting parts.

Type	Description	Quantity included	Length
PA34WB15	Wall brackets for 1 and 1,5 metre units	2 pcs	400 mm
PA34WB20	Wall brackets for 2 metre units	3 pcs	400 mm
PA34WB30	Wall brackets for 2,5 metre units	4 pcs	400 mm
PA34CB15	Ceiling brackets for 1 and 1,5 metre units	4 pcs	
PA34CB20	Ceiling brackets for 2 metre units	6 pcs	
PA34CB30	Ceiling brackets for 2,5 metre units	8 pcs	
PA34WS15	Wire suspension kit for 1 and 1,5 metre units	4 pcs	3 m
PA34WS20	Wire suspension kit for 2 metre units	6 pcs	3 m
PA34WS30	Wire suspension kit for 2,5 metre units	8 pcs	3 m
PA34TR15	Threaded bars for 1 and 1,5 metre units	4 pcs	1 m
PA34TR20	Threaded bars for 2 metre units	6 pcs	1 m
PA34TR30	Threaded bars for 2,5 metre units	8 pcs	1 m
PA34VD15	Vibration dampers for 1 and 1,5 metre units	4 pcs	
PA34VD20	Vibration dampers for 2 metre units	6 pcs	
PA34VD30	Vibration dampers for 2,5 metre units	8 pcs	
PA3JK	Joining kit		

PA3500

Accessories

Horizontal mounting

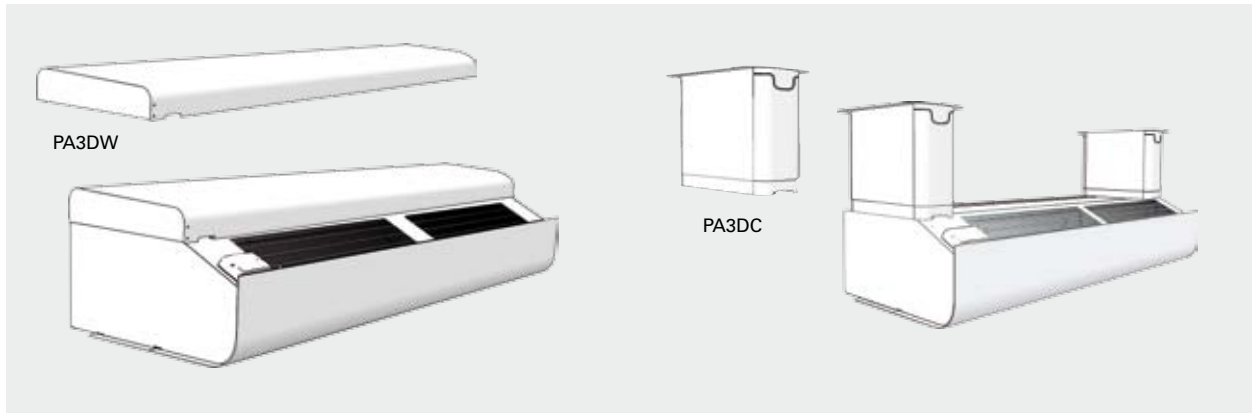

PA3DW, design kit for wall mounting
Used to conceal mountings, cables and pipes. Used together with ceiling brackets PA34WB.

PA3DC, design kit for ceiling mounting
Used to conceal mountings, cables and pipes. The design kit has a telescope function that can be adapted for the installation. It can also be extended with one or more extension parts.

Two design kits are required for 1 and 1.5 metre units, while 2 metre units need three kits and 2.5 metre units needed four kits.

Type	Description	LxHxW [mm]
PA3DW10	Design kit for wall mounting PA3510	87x382x1006
PA3DW15	Design kit for wall mounting PA3515	87x382x1516
PA3DW20	Design kit for wall mounting PA3520	87x382x2006
PA3DW25	Design kit for wall mounting PA3525	87x382x2516

Type	Description
PA3DCS	Design kit for ceiling mounting PA3500, small, 200-300 mm (1 piece)
PA3DCM	Design kit for ceiling mounting PA3500, medium, 300-500 mm (1 piece)
PA3DCL	Design kit for ceiling mounting PA3500, large, 500-900 mm (1 piece)
PA3DXT	Design kit for ceiling mounting PA3500, extension, 420 mm (1 piece)

Recessed mounting in suspended ceilings

PA3XT, outlet extension
Outlet extension with telescopic function. Used for recessed installation of units in suspended ceilings.

Type	Description
PA3XT10	Outlet extension for PA3510, 130-200 mm
PA3XT15	Outlet extension for PA3515, 130-200 mm
PA3XT20	Outlet extension for PA3520, 130-200 mm
PA3XT25	Outlet extension for PA3525, 130-200 mm

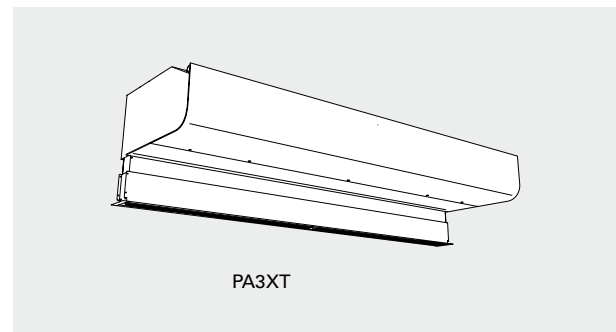

Accessories

Vertical mounting

PA3JK, vertical kit

Used to adapt a horizontal unit for vertical installation. Includes floor frame and mounting parts to support the top. Vertical kit allows two units to be installed on top of each other. One vertical kit is needed per unit.

PA3VDW, design kit for vertical mounting

Used to conceal cables and pipes.

AXP300, collision protection

Floor placed protection against impact from e.g. shopping trolleys.

Type	Description
PA3JK	Vertical kit PA3500
PA3VDW15	Design kit for vertical mounting PA3515
PA3VDW20	Design kit for vertical mounting PA3520
PA3VDW25	Design kit for vertical mounting PA3525
AXP300	Collision protection

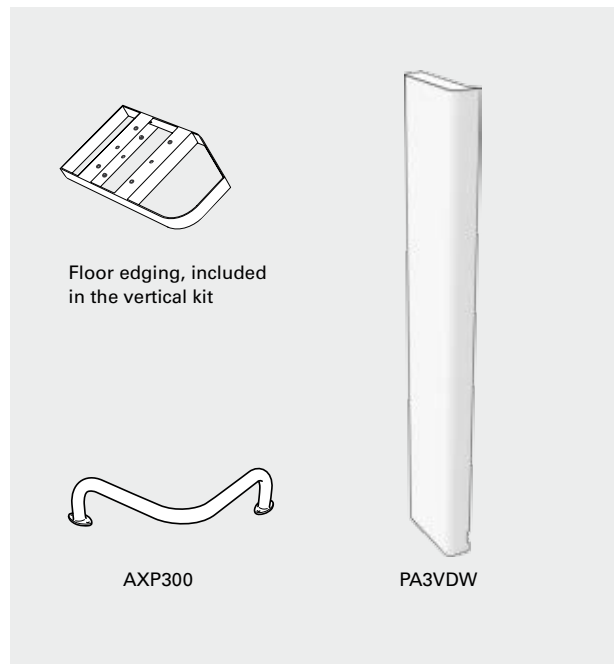

Unit with water heating



PA34EF, external intake filter

Fine mesh filter that prevents ingress of dirt and deposits to water heated units. The filter is easy to attach and remove thanks to the integrated magnetic strips. Makes maintenance easier since the unit does not need to be opened.

DTV200S, filter pressure guard

Measures the differential pressure, which indicates how dirty the filter is in water heated units. The metering hose is connected to the suction side of the unit (after the filter). Adjustment is performed on site depending on the unit and the environment. Adjustable range 20-300 Pa. Potential free, changeover alarm contact.

FHDN20, flexible hoses

Flexible hoses for easy and practical installation of water heated unit.

Type	Description
PA34EF10	External intake filter for 1 metre units
PA34EF15	External intake filter for 1,5 metre units
PA34EF20	External intake filter for 2 metre units
PA34EF25	External intake filter for 2,5 metre units
DTV200S	Filter pressure guard
FHDN20	Flexible hoses DN20, inside thread, 90° bend, 1 pair

Controls

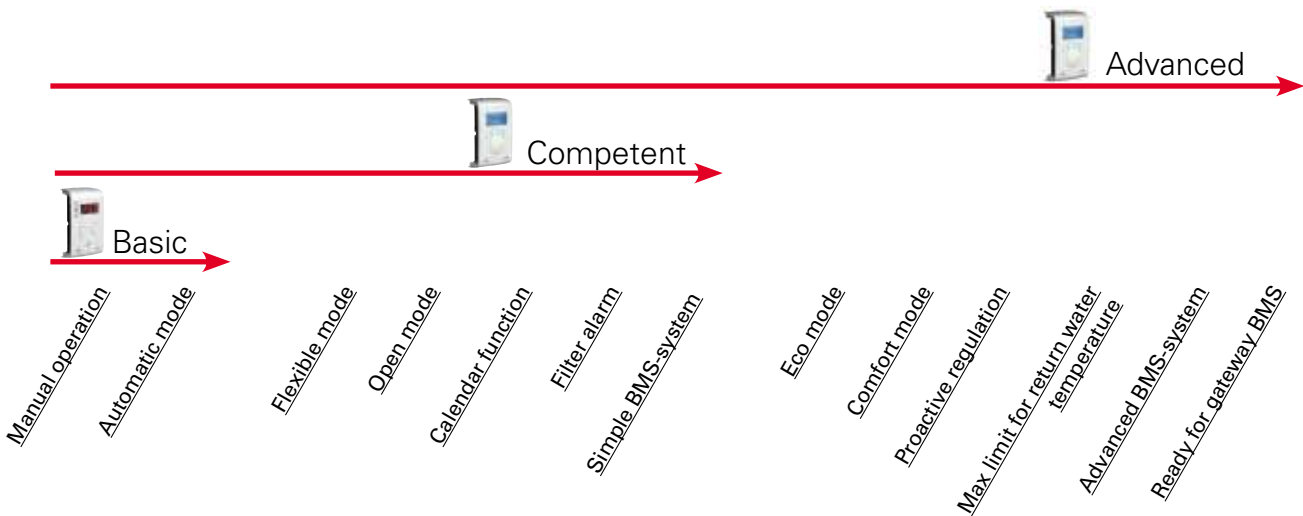

This air curtain is supplied with an integrated PC board SIRE. There are three different levels with different functionality to choose from, Basic, Competent or Advanced. Read more about the SIRE control system in the "Controls" section.

Type	Description
SIREB	Control system SIRE Basic
SIREAC	Control system SIRE Competent
SIREAA	Control system SIRE Advanced

Water control

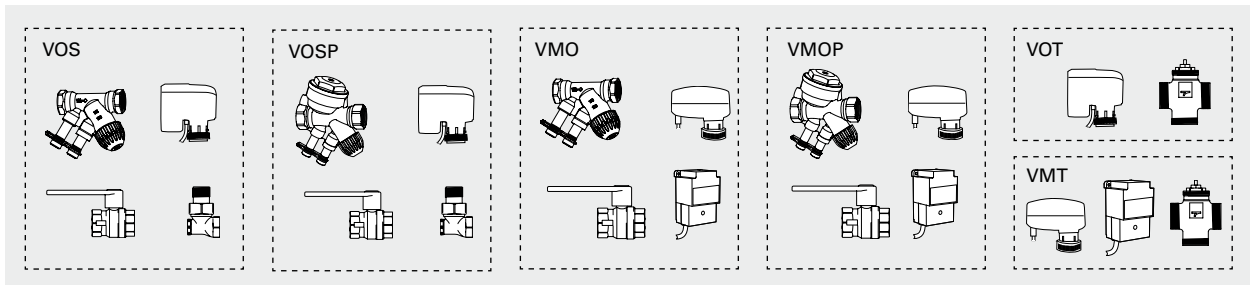

Valve kit VOS(P), VOT, VMO(P) or VMT is used to control the water flow. For more information see the "Controls" section.

Type	Description
VOS15LF	Valve kit on/off, low flow, DN15
VOS15NF	Valve kit on/off, DN15
VOS20	Valve kit on/off, DN20
VOS25	Valve kit on/off, DN25
VOSP15LF	Pressure independent valve kit, low flow, DN15
VOSP15NF	Pressure independent valve kit, DN15
VOSP20	Pressure independent valve kit, DN20
VOSP25	Pressure independent valve kit, DN25
VOT15	Three way control valve and actuator on/off, DN15
VOT20	Three way control valve and actuator on/off, DN20
VOT25	Three way control valve and actuator on/off, DN25

Type	Description
VMO15LF	Modulating valve kit, low flow, DN15
VMO15NF	Modulating valve kit, DN15
VMO20	Modulating valve kit, DN20
VMO25	Modulating valve kit, DN25
VMOP15LF	Pressure independent and modulating valve kit, low flow, DN15
VMOP15NF	Pressure independent and modulating valve kit, DN15
VMOP20	Pressure independent and modulating valve kit, DN20
VMOP25	Pressure independent and modulating valve kit, DN25
VMT15	Three way control valve and modulating actuator, DN15
VMT20	Three way control valve and modulating actuator, DN20
VMT25	Three way control valve and modulating actuator, DN25

Output charts water

PA3500 WH

			Supply water temperature: 110 °C Room temperature: +18 °C Outlet air temperature: +35 °C*1				Water temperature: 110/80 °C Room temperature: +18 °C			
Type	Fan position	Airflow [m³/h]	Output [kW]	Return water temp. [°C]	Water flow [l/s]	Pressure drop [kPA]	Output*2 [kW]	Outlet air temp. [°C]	Water flow [l/s]	Pressure drop [kPA]
PA3510WH	max	1800	10,4	51,1	0,04	1,6	15,3	43,0	0,13	10,1
	min	860	5,0	39,8	0,02	0,3	9,7	51,0	0,08	4,4
PA3515WH	max	2600	15,0	50,4	0,06	0,8	23,0	44,0	0,19	5,6
	min	1240	7,2	41,2	0,03	0,2	14,4	52,2	0,12	2,4
PA3520WH	max	3200	18,5	45,1	0,07	1,2	30,2	45,7	0,25	11,2
	min	1530	8,8	36,4	0,03	0,3	18,8	54,2	0,15	4,8
PA3525WH	max	4600	26,6	48,6	0,11	1,0	41,2	44,2	0,34	8,0
	min	2200	12,7	39,2	0,04	0,2	25,8	52,6	0,21	3,4

			Supply water temperature: 90 °C Room temperature: +18 °C Outlet air temperature: +35 °C*1				Water temperature: 90/70 °C Room temperature: +18 °C			
Type	Fan position	Airflow [m³/h]	Output [kW]	Return water temp. [°C]	Water flow [l/s]	Pressure drop [kPA]	Output*2 [kW]	Outlet air temp. [°C]	Water flow [l/s]	Pressure drop [kPA]
PA3510WH	max	1800	10,4	57,5	0,08	4,6	12,4	38,3	0,15	14,9
	min	860	5,0	43,7	0,03	0,7	7,8	44,8	0,10	6,5
PA3515WH	max	2600	15,0	55,7	0,11	2,1	18,7	39,2	0,23	8,3
	min	1240	7,2	44,2	0,04	0,4	11,7	45,8	0,14	3,6
PA3520WH	max	3200	18,5	51,0	0,12	3,0	24,5	40,5	0,30	16,4
	min	1530	8,8	39,8	0,04	0,5	15,2	47,3	0,19	7,0
PA3525WH	max	4600	26,6	54,5	0,18	2,8	33,4	39,4	0,41	11,8
	min	2200	12,7	42,4	0,07	0,5	21,0	46,0	0,26	5,0

			Supply water temperature: 80 °C Room temperature: +18 °C Outlet air temperature: +35 °C*1				Water temperature: 80/60 °C Room temperature: +18 °C			
Type	Fan position	Airflow [m³/h]	Output [kW]	Return water temp. [°C]	Water flow [l/s]	Pressure drop [kPA]	Output*2 [kW]	Outlet air temp. [°C]	Water flow [l/s]	Pressure drop [kPA]
PA3510WH	max	1800	10,4	61,2	0,14	12,4	10,2	34,7	0,12	10,7
	min	860	5,0	46,3	0,04	1,2	6,4	40,0	0,08	4,7
PA3515WH	max	2600	15,0	58,8	0,17	5,1	15,3	35,3	0,19	5,9
	min	1240	7,2	46,0	0,05	0,6	9,6	40,8	0,12	2,5
PA3520WH	max	3200	18,5	54,7	0,18	6,7	20,1	36,5	0,25	11,8
	min	1530	8,8	42,1	0,06	0,9	12,6	42,4	0,15	5,0
PA3525WH	max	4600	26,6	58,0	0,29	6,7	27,4	35,6	0,34	8,4
	min	2200	12,7	44,7	0,09	0,8	17,2	41,0	0,21	3,6

			Supply water temperature: 82 °C Room temperature: +18 °C Outlet air temperature: +35 °C*1				Water temperature: 82/71 °C Room temperature: +18 °C			
Type	Fan position	Airflow [m³/h]	Output [kW]	Return water temp. [°C]	Water flow [l/s]	Pressure drop [kPA]	Output*2 [kW]	Outlet air temp. [°C]	Water flow [l/s]	Pressure drop [kPA]
PA3510WH	max	1800	10,4	60,4	0,12	9,6	12,1	37,7	0,27	42,1
	min	860	5,0	45,7	0,03	1,1	7,6	44,0	0,17	18,1
PA3515WH	max	2600	15,0	58,2	0,15	4,2	18,2	38,6	0,41	23,8
	min	1240	7,2	45,6	0,05	0,5	11,4	45,0	0,25	10,1
PA3520WH	max	3200	18,5	53,9	0,16	5,5	23,7	39,8	0,53	46,5
	min	1530	8,8	41,6	0,05	0,8	14,7	46,3	0,33	19,5
PA3525WH	max	4600	26,6	57,3	0,26	5,4	32,4	38,8	0,72	33,6
	min	2200	12,7	44,2	0,08	0,7	20,3	45,2	0,45	14,2

*1) Recommended outlet air temperature for good comfort and optimized output.

*2) Nominal output at given supply and return water temperature.

See www.frico.se for additional calculations.

Output charts water

PA3500 WL

			Supply water temperature: 80 °C Room temperature: +18 °C Outlet air temperature: +35 °C*1				Water temperature: 80/60 °C Room temperature: +18 °C			
Type	Fan position	Airflow [m³/h]	Output [kW]	Return water temp. [°C]	Water flow [l/s]	Pressure drop [kPA]	Output*2 [kW]	Outlet air temp. [°C]	Water flow [l/s]	Pressure drop [kPA]
PA3510WL	max	1800	10,4	31,5	0,05	1,2	20,3	51,2	0,25	19,0
	min	860	5,0	29,2	0,02	0,3	12,1	59,2	0,15	7,4
PA3515WL	max	2600	15,0	28,8	0,07	1,5	31,0	53,2	0,38	28,5
	min	1240	7,2	26,6	0,03	0,4	18,1	61,1	0,22	10,8
PA3520WL	max	3200	18,5	28,8	0,09	0,9	39,4	54,2	0,48	18,6
	min	1530	9,0	28,2	0,04	0,3	22,9	62,0	0,28	6,9
PA3525WL	max	4600	26,6	27,7	0,12	2,1	55,4	53,5	0,68	40,9
	min	2200	12,7	24,9	0,06	0,5	32,4	61,4	0,40	15,4

			Supply water temperature: 70 °C Room temperature: +18 °C Outlet air temperature: +35 °C*1				Water temperature: 70/50 °C Room temperature: +18 °C			
Type	Fan position	Airflow [m³/h]	Output [kW]	Return water temp. [°C]	Water flow [l/s]	Pressure drop [kPA]	Output*2 [kW]	Outlet air temp. [°C]	Water flow [l/s]	Pressure drop [kPA]
PA3510WL	max	1800	10,4	33,5	0,07	2,1	16,0	44,2	0,19	12,7
	min	860	5,0	29,8	0,03	0,5	9,6	50,7	0,12	5,0
PA3515WL	max	2600	15,0	30,9	0,09	2,5	24,6	45,9	0,30	19,2
	min	1240	7,2	27,4	0,04	0,6	14,5	52,4	0,18	7,4
PA3520WL	max	3200	18,5	30,6	0,11	1,5	31,2	46,7	0,38	12,5
	min	1530	8,8	28,4	0,05	0,4	18,2	53,1	0,22	4,8
PA3525WL	max	4600	26,5	29,8	0,16	3,3	44,1	46,2	0,54	27,6
	min	2200	12,7	26,0	0,07	0,8	26,0	52,7	0,32	10,6

			Supply water temperature: 60 °C Room temperature: +18 °C Outlet air temperature: +35 °C*1				Water temperature: 60/40 °C Room temperature: +18 °C			
Type	Fan position	Airflow [m³/h]	Output [kW]	Return water temp. [°C]	Water flow [l/s]	Pressure drop [kPA]	Output*2 [kW]	Outlet air temp. [°C]	Water flow [l/s]	Pressure drop [kPA]
PA3510WL	max	1800	10,4	36,0	0,11	4,5	11,7	37,1	0,14	7,4
	min	860	5,0	31,0	0,04	0,9	7,0	42,0	0,08	3,0
PA3515WL	max	2600	15,0	33,7	0,14	5,0	18,1	38,5	0,22	11,3
	min	1240	7,2	28,9	0,06	1,0	10,7	43,5	0,13	4,5
PA3520WL	max	3200	18,5	33,1	0,17	3,0	22,8	39,1	0,28	7,4
	min	1530	8,8	29,2	0,07	0,7	13,5	43,9	0,16	2,9
PA3525WL	max	4600	26,6	32,9	0,24	6,7	32,6	38,9	0,39	16,5
	min	2200	12,7	27,8	0,09	1,4	19,3	43,9	0,23	6,5

			Supply water temperature: 55 °C Room temperature: +18 °C Outlet air temperature: +35 °C*1				Water temperature: 55/35 °C Room temperature: +18 °C			
Type	Fan position	Airflow [m³/h]	Output [kW]	Return water temp. [°C]	Water flow [l/s]	Pressure drop [kPA]	Output*2 [kW]	Outlet air temp. [°C]	Water flow [l/s]	Pressure drop [kPA]
PA3510WL	max	1800	10,4	37,9	0,15	8,1	9,4	33,4	0,11	5,2
	min	860	5,0	31,9	0,05	1,3	5,7	37,4	0,07	2,1
PA3515WL	max	2600	15,0	35,5	0,19	8,6	14,7	34,7	0,18	8,0
	min	1240	7,1	29,9	0,07	1,5	8,7	38,9	0,10	3,1
PA3520WL	max	3200	18,5	34,8	0,22	5,0	18,6	35,1	0,23	5,2
	min	1530	8,9	30,1	0,09	1,0	11,1	39,1	0,13	2,1
PA3525WL	max	4600	26,6	34,9	0,32	11,6	26,7	35,1	0,32	11,7
	min	2200	12,7	29,0	0,12	2,0	15,9	39,3	0,19	4,7

*1) Recommended outlet air temperature for good comfort and optimized output.

*2) Nominal output at given supply and return water temperature.

See www.frico.se for additional calculations.

Output charts water

PA3500 WLL

			Supply water temperature: 55 °C Room temperature: +18 °C Outlet air temperature: +32 °C				Water temperature: 55/35 °C Room temperature: +18 °C			
Type	Fan position	Airflow [m³/h]	Output [kW]	Return water temp. [°C]	Water flow [l/s]	Pressure drop [kPA]	Output* [kW]	Outlet air temp. [°C]	Water flow [l/s]	Pressure drop [kPA]
PA3510WLL	max	1700	8,1	28,3	0,07	1,5	11,2	37,4	0,14	4,3
	min	830	3,9	27,9	0,04	0,4	6,5	41,1	0,08	1,7
PA3515WLL	max	2500	11,9	29,4	0,11	0,7	16,3	37,2	0,20	1,9
	min	1200	5,7	30,7	0,06	0,2	9,2	40,5	0,11	0,7
PA3520WLL	max	3050	14,5	26,7	0,12	1,1	21,9	39,2	0,26	4,0
	min	1460	6,9	27,6	0,11	0,4	12,3	42,8	0,15	1,5
PA3525WLL	max	4400	20,8	27,5	0,18	1,1	30,3	38,3	0,37	3,6
	min	2100	10,0	28,1	0,10	0,4	17,1	42,0	0,21	1,3

			Supply water temperature: 50 °C Room temperature: +18 °C Outlet air temperature: +32 °C				Water temperature: 50/30 °C Room temperature: +18 °C			
Type	Fan position	Airflow [m³/h]	Output [kW]	Return water temp. [°C]	Water flow [l/s]	Pressure drop [kPA]	Output* [kW]	Outlet air temp. [°C]	Water flow [l/s]	Pressure drop [kPA]
PA3510WLL	max	1700	8,1	29,2	0,09	2,3	8,4	32,6	0,10	2,7
	min	830	3,9	27,7	0,04	0,6	4,8	35,2	0,06	1,0
PA3515WLL	max	2500	11,9	30,0	0,14	1,1	11,9	32,0	0,14	1,1
	min	1200	5,7	29,9	0,07	0,3	6,0	32,6	0,07	0,3
PA3520WLL	max	3050	14,5	27,6	0,16	1,6	16,7	34,2	0,20	2,6
	min	1460	4,9	27,0	0,07	0,4	9,3	36,8	0,10	0,9
PA3525WLL	max	4400	20,8	28,4	0,23	1,7	23,0	33,4	0,28	2,3
	min	2100	10,0	27,4	0,11	0,4	12,9	36,0	0,16	0,8

			Supply water temperature: 45 °C Room temperature: +18 °C Outlet air temperature: +32 °C				Water temperature: 45/35 °C Room temperature: +18 °C			
Type	Fan position	Airflow [m³/h]	Output [kW]	Return water temp. [°C]	Water flow [l/s]	Pressure drop [kPA]	Output* [kW]	Outlet air temp. [°C]	Water flow [l/s]	Pressure drop [kPA]
PA3510WLL	max	1700	8,1	30,6	0,14	4,4	9,7	34,8	0,23	11,6
	min	830	3,9	28,0	0,06	1,0	5,6	37,8	0,13	4,4
PA3515WLL	max	2500	11,9	30,8	0,20	2,1	14,4	34,9	0,35	5,4
	min	1200	5,7	29,3	0,09	0,5	8,1	37,8	0,19	1,9
PA3520WLL	max	3050	14,5	28,8	0,22	2,9	18,7	36,0	0,45	10,6
	min	1460	6,9	27,0	0,09	0,7	10,4	38,9	0,25	3,7
PA3525WLL	max	4400	20,8	29,7	0,33	3,1	26,0	35,4	0,63	9,7
	min	2100	10,0	27,5	0,14	0,7	14,6	38,4	0,35	3,4

			Supply water temperature: 40 °C Room temperature: +18 °C Outlet air temperature: +32 °C				Water temperature: 40/30 °C Room temperature: +18 °C			
Type	Fan position	Airflow [m³/h]	Output [kW]	Return water temp. [°C]	Water flow [l/s]	Pressure drop [kPA]	Output* [kW]	Outlet air temp. [°C]	Water flow [l/s]	Pressure drop [kPA]
PA3510WLL	max	1700	8,1	32,6	0,26	14,5	7,2	30,5	0,17	7,0
	min	830	3,9	29,0	0,09	2,1	4,2	32,8	0,10	2,7
PA3515WLL	max	2500	11,9	32,4	0,38	6,3	10,5	30,4	0,25	3,2
	min	1200	5,7	29,5	0,13	1,0	5,9	32,5	0,14	1,2
PA3520WLL	max	3050	14,5	30,8	0,38	8,0	14,0	31,5	0,34	6,5
	min	1460	6,9	27,4	0,05	0,2	7,8	33,8	0,19	2,3
PA3525WLL	max	4400	20,8	31,6	0,60	9,2	19,4	31,0	0,47	5,9
	min	2100	10,0	28,4	0,21	1,4	10,9	33,3	0,26	2,1

*) Nominal output at given supply and return water temperature.

See www.frico.se for additional calculations.

PA3500

Wiring diagrams

Internal wiring diagram

Unit without heating

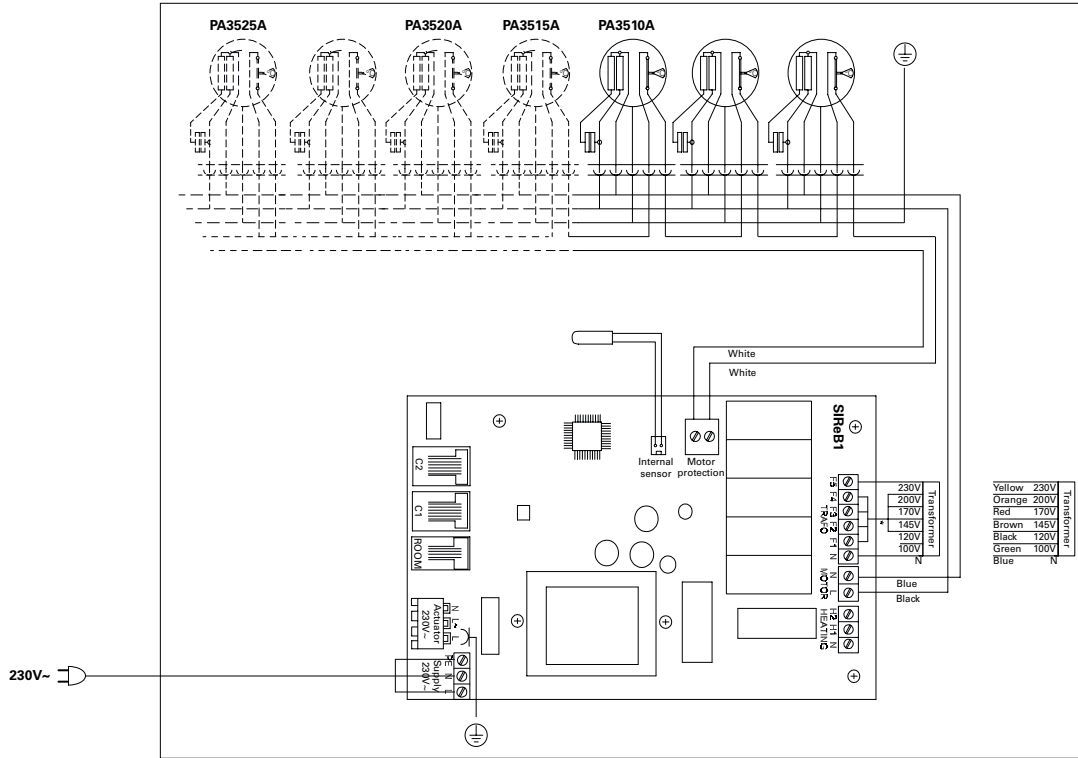

Unit with electrical heating

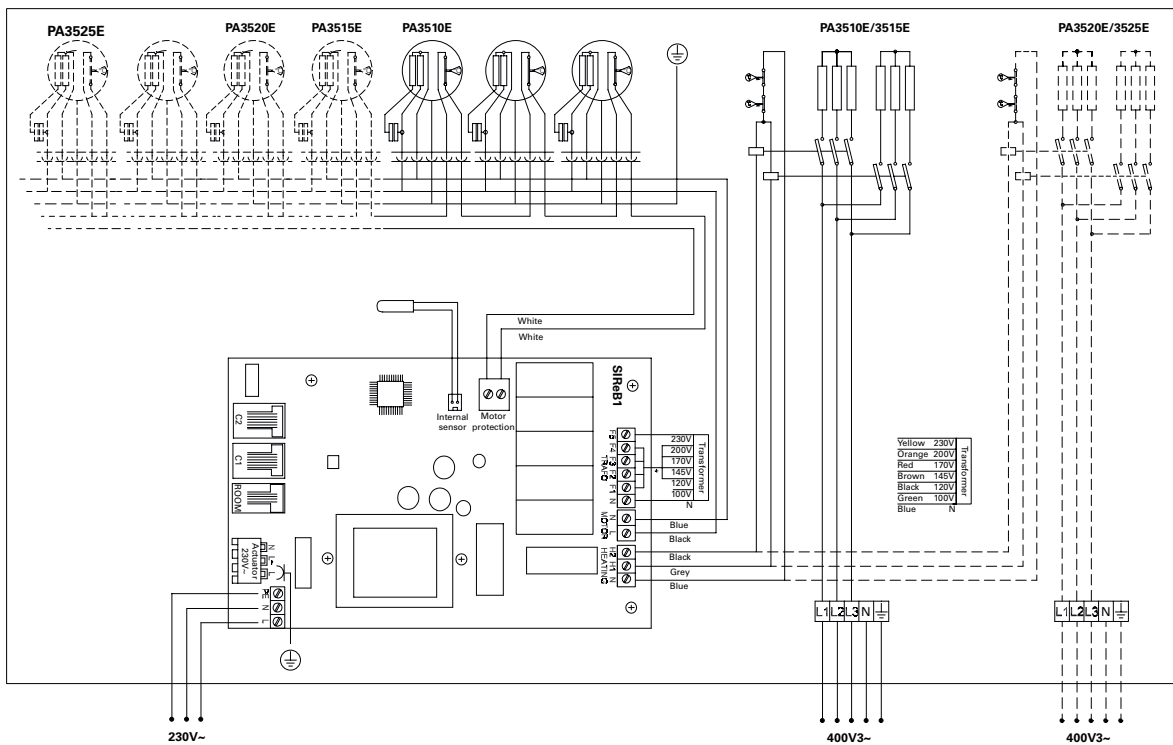

Wiring diagrams

Internal wiring diagram

Unit with water heating

